

to 1.6µm, i.e., a roughness number N7 or less.

33.5 The shot shall conform to the following specifications:

Minimum weight and diameter limits for admission to competition and acceptance of a Record:					
Diameter	3.000kg	4.000kg	5.000kg	6.000kg	7.260kg
Minimum	85mm	95mm	100mm	105mm	110mm
Maximum	110mm	110mm	120mm	125mm	130mm

Team of Officials

For a Shot Put event, it is recommended to allocate the available officials as follows:

- a. The Chief Judge will watch over the whole of the event.
- b. Two Judges checking whether the put has been made correctly and measuring the trial. One must be provided with two flags - white to indicate if the trial is valid and red if it is a failure. When the put has been measured, it is advised that the Judge stands in the circle holding the red flag, while the implement is returned and the landing area is cleared. A cone may be placed in the circle instead. (In some competitions this position is assumed by the Chief Judge of the event.)

Where EDM is not in use, the second Judge should pull through and hold the measuring tape in such a way that it passes through the centre of the circle.

- c. Judge immediately after the throw placing a marker indicating the point from which the trial is to be measured.
- d. Judge positioning the spike/prism at the point where the marker has been placed ensuring the tape is on the zero mark.
- e. Judge in charge of retrieving the implements and returning them to the implement stand or placing them in the return chute.
- f. Judge - a recorder scoring the results sheet and calling each athlete (and the one who is to follow).
- g. Judge in charge of the scoreboard (trial-number-result).
- h. Judge in charge of the clock indicating to the athletes that they have a certain time to take their trial.
- i. Judge in charge of athletes.
- j. Judge in charge of the implement stand.

Note (i): This is the traditional setting-up of the officials. In major competitions, where a data system and electronic scoreboards are available, specialised personnel are certainly required. To be clear in these cases, the progress and scoring of a Field Event is followed by both the recorder and by the data system.

Note (ii): Officials and equipment must be placed in such a way as not to obstruct the athlete's way nor impede the view of the spectators.

34. Discus Throw

Discus

- 34.1 The body of the discus may be solid or hollow and shall be made of wood, or other suitable material, with a metal rim, the edge of which shall be circular. The cross section of the edge shall be rounded in a true circle having a radius of approximately 6mm. There may be circular plates set flush into the centre of the sides. The plates shall be tightly fixed and not able to be rotated. Alternatively, the discus may be made without metal plates, provided that the equivalent area is flat and the measurements and total weight of the implement correspond to the specifications. There shall be no loose parts.

Each side of the discus shall be identical and shall be made without indentations, projections or sharp edges. The sides shall taper in a straight line from any point on a circle of a radius of 25mm to 28.5mm from the centre of the discus to the beginning of the curve of the rim.

The profile of the discus shall be designed as follows. From the beginning of the curve of the rim the thickness of the discus increases regularly up to the maximum thickness D. This maximum value is achieved at a distance of 25 mm to 28.5mm from the axis of the discus Y. From this point up to the axis Y, the thickness of the discus is constant. The upper and lower side of the discus must be identical. Also, the discus has to be symmetrical concerning rotation around the axis Y.

The discus, including the surface of the rim, shall have no roughness and the finish shall be smooth (see Rule 33.4 of the Technical Rules) and uniform throughout.

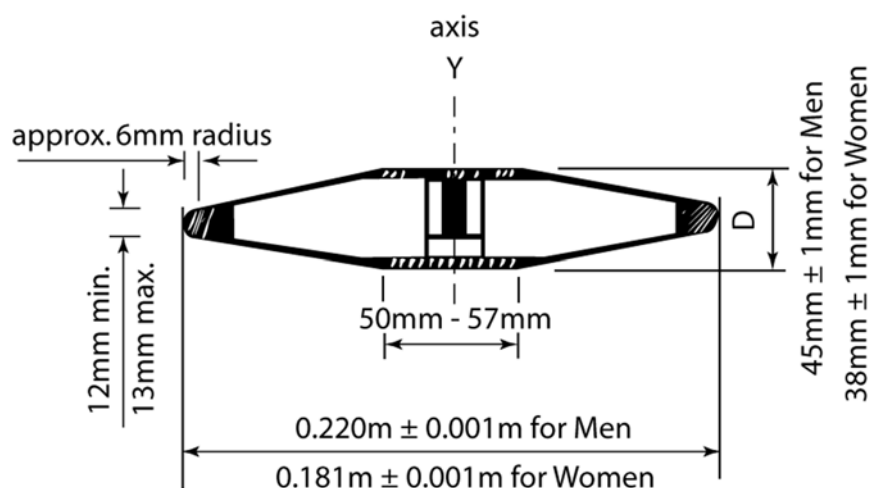

Figure TR34– Discus

- 34.2 The discus shall conform to the following specifications:

Minimum weight and diameter limits for admission to competition and acceptance of a Record:				
	1.000kg	1.500kg	1.750kg	2.000kg
Outside diameter of metal rim:				
Minimum	180mm	200mm	210mm	219mm
Maximum	182mm	202mm	212mm	221mm
Diameter of metal plate or flat centre area:				
Minimum	50mm	50mm	50mm	50mm
Maximum	57mm	57mm	57mm	57mm
Thickness of metal plate or flat centre area:				
Minimum	37mm	38mm	41mm	44mm
Maximum	39mm	40mm	43mm	46mm
Thickness of metal rim (6mm from edge):				
Minimum	12mm	12mm	12mm	12mm

Maximum	13mm	13mm	13mm	13mm
---------	------	------	------	------

Team of Officials

For a Discus Throw event, it is recommended to allocate the available officials as follows:

- a. The Chief Judge will watch over the whole of the event.
- b. Two Judges checking whether the throw has been made correctly and measuring the trial. One must be provided with two flags - white to indicate if the trial is valid and red if it is a failure. When the throw has been measured, it is advised that the Judge stands at the entrance to the cage holding the red flag, while the implement is returned and the landing area is cleared. A cone may be placed at this point instead. (In some competitions this position is assumed by the Chief Judge of the event.)

Where EDM is not in use the second Judge should pull through and hold the measuring tape in such a way that it passes through the centre of the circle.

- c. Judge immediately after the throw placing a marker indicating the point from which the trial is to be measured. If the implement lands outside the sector either this Judge or the one with the spike/prism (whichever is closer to the line) should indicate this by holding their arm outstretched. No indication is required for a valid trial.
- d. Judge positioning the spike/prism at the point where the marker has been placed ensuring the tape is on the zero mark.
- e. one or more Judges or assistants in charge of retrieving the implements and returning them to the implement stand or placing them in the return device. Where a tape is used for measurement, one of these Judges or assistants should ensure that the tape measure is taut in order to ensure a correct measurement.
- f. Judge - a recorder scoring the results sheet and calling each athlete (and the one who is to follow).
- g. Judge in charge of the scoreboard (trial-number-result).
- h. Judge in charge of the clock indicating to the athletes that they have a certain time to take their trial.
- i. Judge in charge of athletes.
- j. Judge in charge of the implement stand.

Note (i): This is the traditional setting-up of the officials. In major competitions, where a data system and electronic scoreboards are available, specialised personnel are certainly required. To be clear in these cases, the progress and scoring of a Field Event is followed by both the recorder and by the data system.

Note (ii): Officials and equipment must be placed in such a way as not to obstruct the athlete's way nor impede the view of the spectators.

Note (iii): A space must be reserved for a wind-sock to indicate the wind direction and strength.

35. Discus Cage

- 35.1 All discus throws shall be made from an enclosure or cage to ensure the safety of spectators, officials and athletes. The cage specified in this Rule is intended for use when the event takes place in the Field of Play with other events taking place at the same time or when the event takes

place outside the Field of Play with spectators present. Where this does not apply, and especially in training areas, a much simpler construction may be satisfactory. Advice is available, on request, from Members or from the World Athletics Office.

Note (i): The hammer cage specified in Rule 37 of the Technical Rules may also be used for Discus Throw, either by installing 2.135/2.50m concentric circles, or by using the extension of the gates of that cage with a separate discus circle installed in front of the hammer circle.

Note (ii): The hammer cage movable panels may be used when the cage is being used for discus throw to limit the danger zone.

- 35.2 The cage should be designed, manufactured and maintained so as to be capable of stopping a 2kg discus moving at a speed of up to 25 metres per second. The arrangement should be such that there is no danger of ricocheting or rebounding back towards the athlete or over the top of the cage. Provided that it satisfies all the requirements of this Rule, any form of cage design and construction can be used.
- 35.3 The cage should be U-shaped in plan as shown in Figure TR35. The width of the mouth should be 6m, positioned 7m in front of the centre of the throwing circle. The end points of the 6m wide mouth shall be the inner edge of the cage netting. The height of the netting panels or draped netting at their lowest point should be at least 4m and it should be at least 6m for the 3m nearest the front of the cage on each side.

Provision should be made in the design and construction of the cage to prevent a discus forcing its way through any joints in the cage or the netting or underneath the netting panels or draped netting.

Note (i): The arrangement of the rear panels/netting is not important provided the netting is a minimum of 3.00m away from the centre of the circle.

Note (ii): Innovative designs that provide the same or better degree of protection and do not increase the danger zone compared with conventional designs may be World Athletics certified.

Note (iii): The cage side, particularly alongside the track, may be lengthened, and/or provided with (a) movable panel(s), and/or increased in height so as to provide greater protection to athletes competing on the adjoining track during a discus competition.

The netting must be fixed in a way that the width of the mouth is the same at each height of the netting. This applies also for the panels when put into a position according to Rule 37.4 of the Technical Rules Note (ii).

- 35.4 The netting for the cage can be made from suitable natural or synthetic fibre cord or, alternatively, from mild or high tensile steel wire. The measurement of the mesh cord centres shall be a maximum of 45mm for cord netting and 50mm for steel wire netting.

Note: Further specifications for the netting and safety inspection procedures are set out in the World Athletics Track and Field Facilities Manual.

- 35.5 The maximum danger sector for discus throws from this cage is approximately 69°, when used by both right and left handed throwers in the same competition (calculated by assuming that the discus is released from a circumscribed circle of 1.5m radius). The position and alignment of the cage in the Field of Play is, therefore, critical for its safe use.

Note (i): The method used to determine the danger zone is illustrated in Figure TR35.

Note (ii): At each competition site, a danger zone plan for display at the venue should be prepared that plots the danger zone for the location of each throwing cage considering its configuration and orientation.

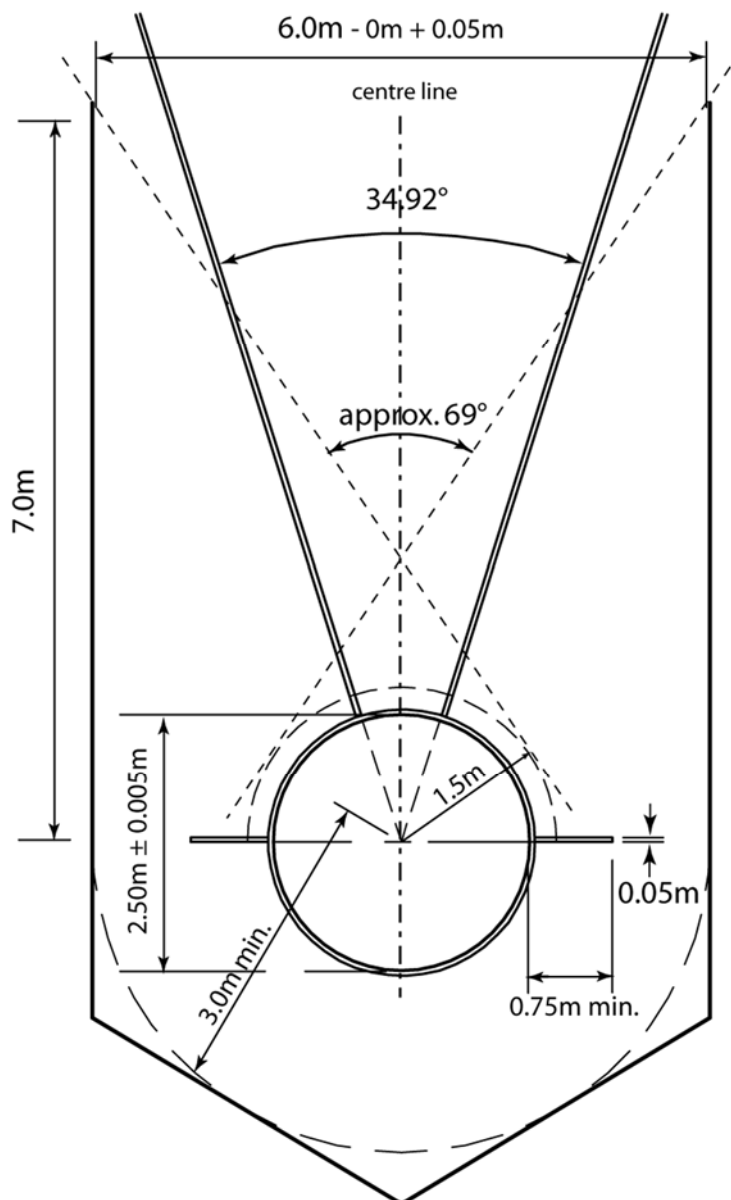

Figure TR35 - Cage for Discus Throw only (with cage dimensions to netting)

36. Hammer Throw

Competition

- 36.1 An athlete, in their starting position prior to the preliminary swings or turns, is allowed to put the head of the hammer on the ground inside or outside the circle.
- 36.2 It shall not be considered a failure if the head of the hammer touches the ground inside or outside the circle, or the top of the rim. The athlete may stop and begin the throw again, provided no other