

Note (ii): At each competition site, a danger zone plan for display at the venue should be prepared that plots the danger zone for the location of each throwing cage considering its configuration and orientation.

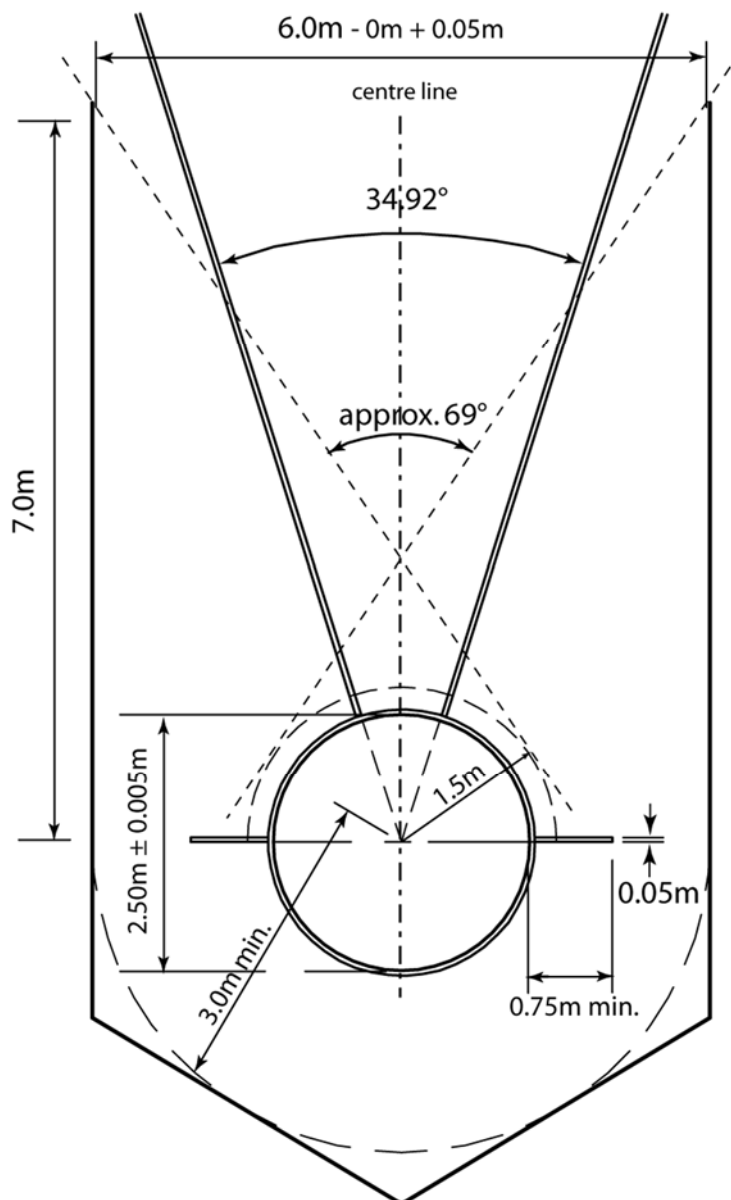

Figure TR35 - Cage for Discus Throw only (with cage dimensions to netting)

36. Hammer Throw

Competition

- 36.1 An athlete, in their starting position prior to the preliminary swings or turns, is allowed to put the head of the hammer on the ground inside or outside the circle.
- 36.2 It shall not be considered a failure if the head of the hammer touches the ground inside or outside the circle, or the top of the rim. The athlete may stop and begin the throw again, provided no other

Rule has been breached.

- 36.3 If the hammer breaks during a throw or while in the air, it shall not count as a failure, provided the trial was otherwise made in accordance with this Rule. Nor shall it count as a failure if an athlete thereby loses their balance and as a result contravenes any part of this Rule. In both cases the athlete shall be awarded a replacement trial.

Hammer

- 36.4 The hammer shall consist of three main parts: a metal head, a wire and a handle.
- 36.5 The head shall be of solid iron, brass or other metal not softer than brass or a shell of such metal filled with lead or other solid material.

The centre of gravity of the head shall be not more than 6mm from the centre of the sphere, i.e. - it must be possible to balance the head, less handle and wire, on a horizontal sharp-edged circular orifice 12mm in diameter (see Figure (a) TR36). If a filling is used, this shall be inserted in such manner that it is immovable and complies with the requirement for the centre of gravity.

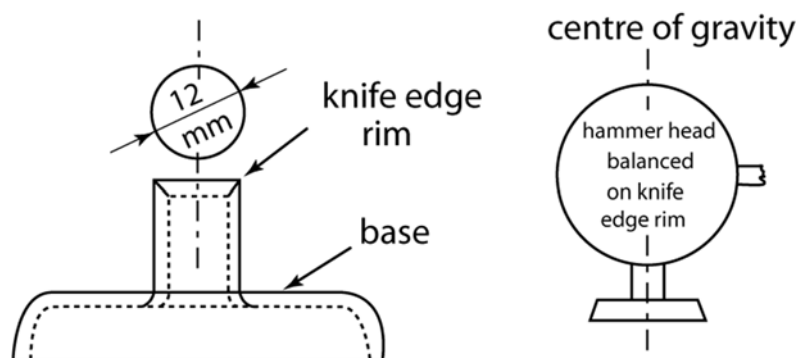

Figure (a) TR36 - Suggested apparatus for testing centre of gravity of hammer head

- 36.6 The wire shall be a single unbroken and straight length of spring steel wire not less than 3mm in diameter and shall be such that it cannot stretch appreciably while the hammer is being thrown.

The wire may be looped at one or both ends as a means of attachment. The wire shall be connected to the head by means of a swivel, which may be either plain or ball bearing.

Note: A small section of clear vinyl tubing 50mm long with an internal diameter of 5mm may be placed over the twisted ends of the hammer wire.

- 36.7 The handle shall be rigid and without hinging joints of any kind. The total deformation of the handle under a tension load of 3.8kN shall not exceed 3mm. It shall be attached to the wire in such a manner that it cannot be turned within the loop of the wire to increase the overall length of the hammer. The handle shall be connected to the wire by means of a loop. A swivel may not be used.

The handle shall have a symmetric design and may have a curved or straight grip and/or brace. The minimum handle breaking strength shall be 8kN.

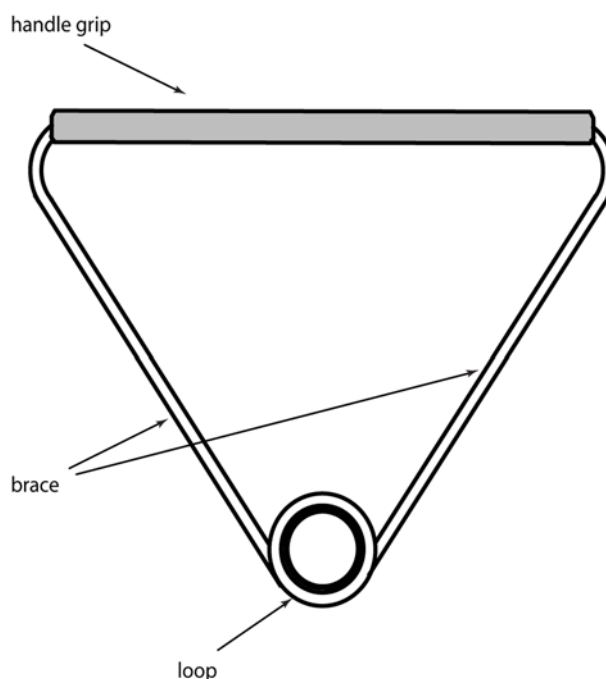

Figure (b) TR36- Generic hammer handle

Note: Other designs complying with the specifications are acceptable.

36.8 The hammer shall conform to the following specifications:

Minimum weight and diameter limits for admission to competition and acceptance of a Record:					
	3.000kg	4.000kg	5.000kg	6.000kg	7.260kg
Length of hammer measured from inside of handle:					
Maximum	1195mm	1195mm	1200mm	1215mm	1215mm
Diameter of head:					
Minimum	85mm	95mm	100mm	105mm	110mm
Maximum	100mm	110mm	120mm	125mm	130mm

Note: The weight of the implement includes the totality of the hammer head, wire and handle.

Team of Officials

For a Hammer Throw event, it is recommended to allocate the available officials as follows:

- a. The Chief Judge will watch over the whole of the event.
- b. Two Judges checking whether the throw has been made correctly and measuring the trial. One must be provided with two flags - white to indicate if the trial is valid and red if it is a failure. When the throw has been measured, it is advised that the Judge stands at the entrance to the cage holding the red flag, while the implement is returned and the landing area is cleared. A cone may be placed at this point instead. (In some competitions this position is assumed by the Chief Judge of the event.)

Where EDM is not in use, the second Judge should pull through and hold the measuring tape in such a way that it passes through the centre of the circle.

- c. Judge immediately after the throw placing a marker indicating the point from which the trial is to be measured. If the implement lands outside the sector either this Judge or the one with the spike/prism (whichever is closer to the line) should indicate this by holding their arm outstretched. No indication is required for a valid trial.
- d. Judge positioning the spike/prism at the point where the marker has been placed ensuring the tape is on the zero mark.
- e. one or more Judges or assistants in charge of retrieving the implements and returning them to the implement stand or placing them in the return device. Where a tape is used for measurement, one of these Judges or assistants should ensure that the tape measure is taut in order to ensure a correct measurement.
- f. Judge - a recorder scoring the results sheet and calling each athlete (and the one who is to follow).
- g. Judge in charge of the scoreboard (trial-number-result).
- h. Judge in charge of the clock indicating to the athletes that they have a certain time to take their trial.
- i. Judge in charge of athletes.
- j. Judge in charge of the implement stand.

Note (i): This is the traditional setting-up of the officials. In major competitions, where a data system and electronic scoreboards are available, specialised personnel are certainly required. To be clear in these cases, the progress and scoring of a Field Event is followed by both the recorder and by the data system.

Note (ii): Officials and equipment must be placed in such a way as not to obstruct the athlete's way nor impede the view of the spectators.

37. Hammer Cage

- 37.1 All hammer throws shall be made from an enclosure or cage to ensure the safety of spectators, officials and athletes. The cage specified in this Rule is intended for use when the event takes place in the Field of Play with other events taking place at the same time or when the event takes place outside the Field of Play with spectators present. Where this does not apply, and especially in training areas, a much simpler construction may be satisfactory. Advice is available on request from Members or from the World Athletics Office.
- 37.2 The cage should be designed, manufactured and maintained so as to be capable of stopping a 7.260kg hammer head moving at a speed of up to 32 metres per second. The arrangement should be such that there is no danger of ricocheting or rebounding back towards the athlete or over the top of the cage. Provided that it satisfies all the requirements of this Rule, any form of cage design and construction can be used.
- 37.3 The cage should be U-shaped in plan as shown in Figure (a) TR37. The width of the mouth should be 6m, positioned 7m in front of the centre of the throwing circle. The end points of the 6m wide mouth shall be the inner edge of the pivoted netting. The height of the netting panels or draped netting at their lowest point shall be at least 7m for the panels/netting at the rear of the cage and at least 10m for the last 2.80m panels to the gate netting pivot points.

Provisions should be made in the design and construction of the cage to prevent a hammer forcing its way through any joints in the cage or the netting or underneath the netting panels or draped netting.

Note (i): The arrangement of the rear panels / netting is not important provided the netting is a minimum of 3.50m away from the centre of the circle.

Note (ii): Any number of posts may be used to support the netting in the position shown in Figures TR37.

- 37.4 Two movable netting panels 2m wide shall be provided at the front of the cage, only one of which will be operative at a time. The minimum height of the panels shall be 10m.

Note (i): The left hand panel is used for throwers turning anti clockwise, and the right hand panel for throwers turning clockwise. In view of the possible need to change over from one panel to the other during the competition, when both left and right-handed throwers are present, it is essential that this changeover should require little labour and be carried out in the minimum of time.

Note (ii): The end position of both panels is shown in the plan even though only one panel will be closed at any one time during competition.

Note (iii): When in operation, the movable panel shall be exactly in the position shown. Provision shall therefore, be made in the design of the movable panels to lock them in the operative position. It is recommended to mark (either temporarily or permanently) the operative positions of the panels on the ground.

Note (iv): The construction of these panels and their operation depends on the overall design of the cage and can be sliding, hinging on a vertical or horizontal axis or dismounting. The only firm requirements are that the panel in operation shall be fully able to stop any hammer striking it and there shall be no danger of a hammer being able to force its way between the fixed and movable panels.

Note (v): Innovative designs that provide the same or better degree of protection and do not increase the danger zone compared with conventional designs may be World Athletics certified.

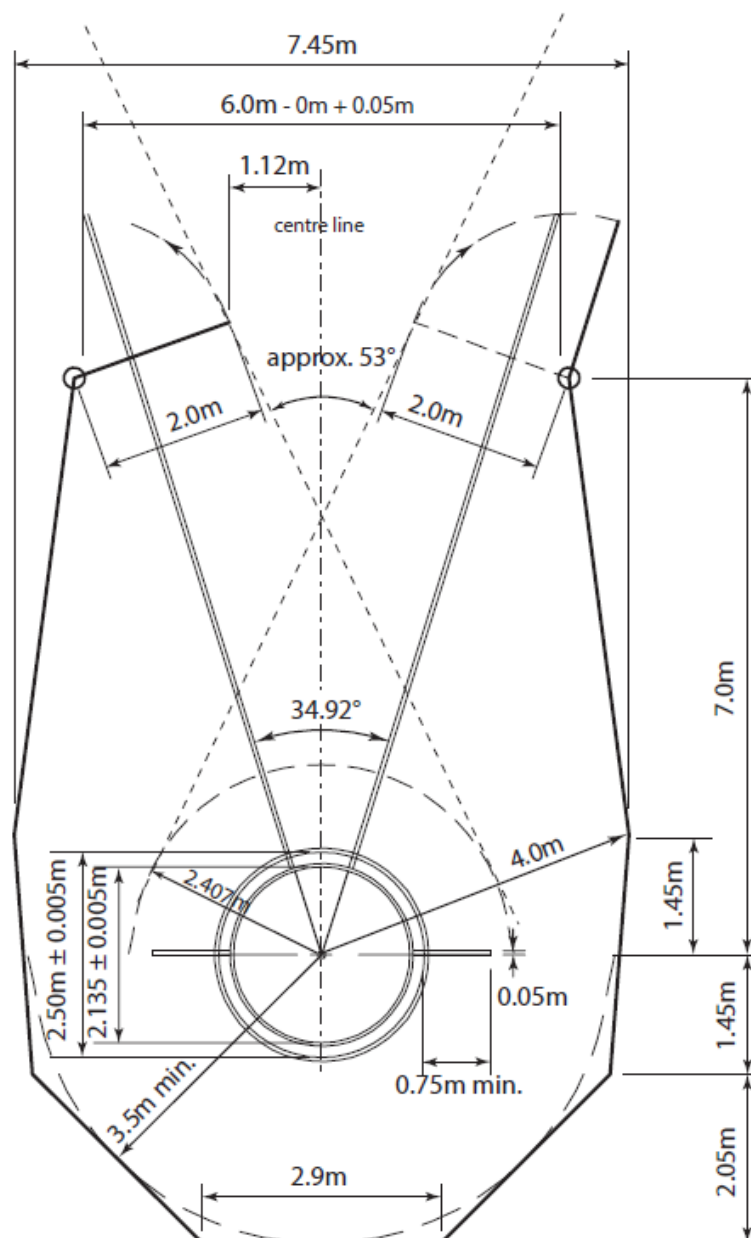

Figure (a) TR37 - Cage for Hammer and Discus Throw with concentric circles (Hammer Throw configuration for right-handed thrower with cage dimensions to netting)

- 37.5 The netting for the cage can be made from suitable natural or synthetic fibre cord or, alternatively, from mild or high tensile steel wire. The measurement of the mesh cord centres shall be a maximum of 45mm for cord netting and 50mm for steel wire netting.

Note: Further specifications for the netting and safety inspection procedures are set out in the World Athletics Track and Field Facilities Manual.

- 37.6 Where it is desired to use the same cage for Discus Throw, the installation can be adapted in two alternative ways. Most simply, a 2.135m/2.50m concentric circle may be fitted, but this involves using the same surface in the circle for Hammer Throw and Discus Throw. The hammer cage shall be used for Discus Throw by fixing the movable netting panels clear of the cage opening.

For separate circles for Hammer Throw and Discus Throw in the same cage, the two circles shall be placed one behind the other with the centres 2.37m apart on the centre line of the landing sector and with the discus circle at the front. In that case, the movable netting panels shall be used for Discus Throw in order to lengthen the cage sides.

Note: The arrangement of the rear panels/draped netting is not important provided the netting is a minimum of 3.50m away from the centre of concentric circles or the hammer circle in case of separate circles (or 3.00m for cages with separate circles built under the Rule in force before 2004 with the discus circle at the back) (see also Rule 37.4 of the Technical Rules).

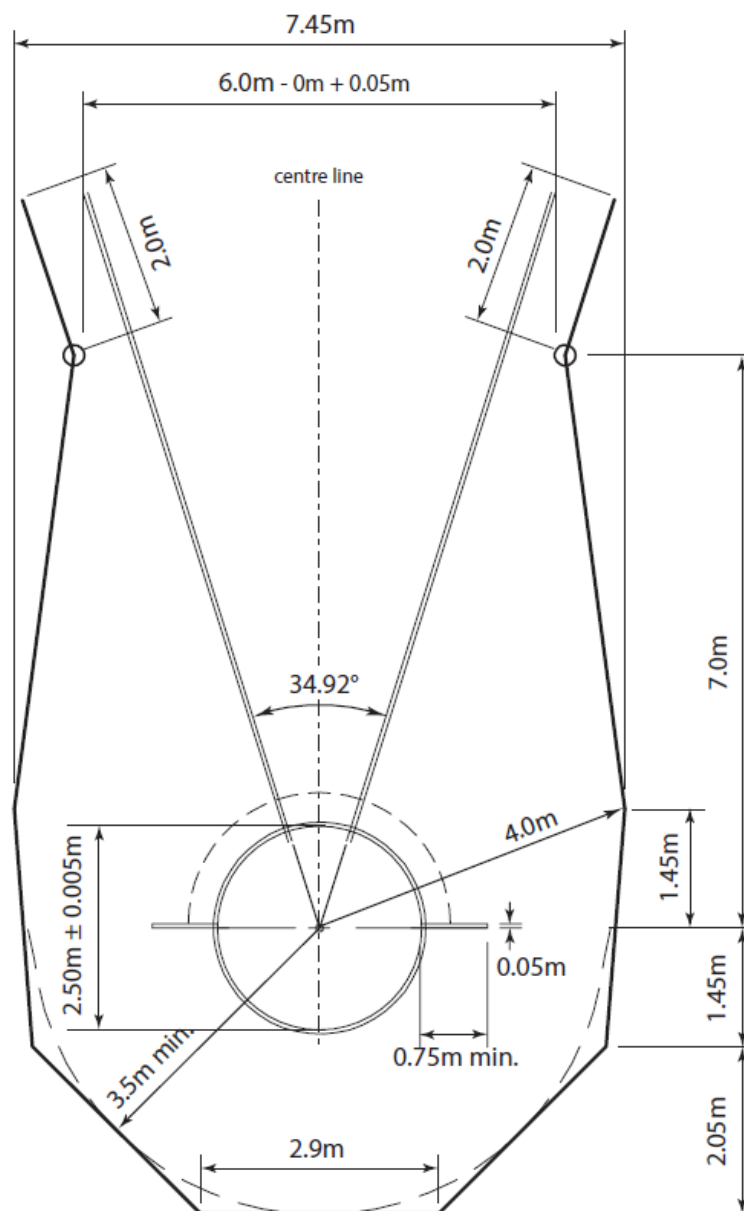

Figure (b) TR37 - Cage for Hammer and Discus Throw with concentric circles (Discus Throw configuration, with cage dimensions to netting)

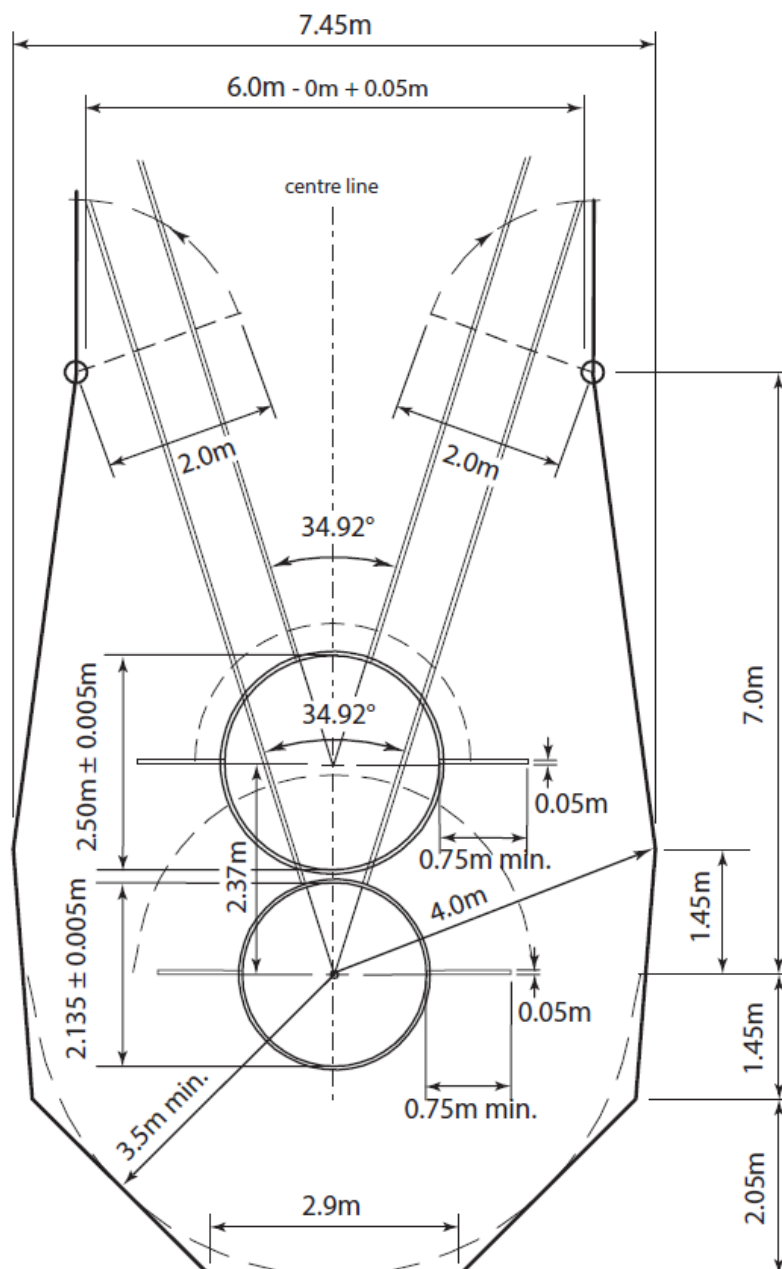

Figure (c) TR37 - Cage for Hammer and Discus Throw with separate circles (With cage dimensions to netting) (Only if the discus circle is in front of the hammer circle. For Hammer Throw, the gate should be as in Figure (a) TR37.)

- 37.7 The maximum danger sector for hammer throws from this cage is approximately 53° , when used by both right and left-handed throwers in the same competition (calculated by assuming that the hammer is released from a circumscribed circle of 2.407m radius). The position and alignment of the cage in the Field of Play is, therefore, critical for its safe use.

Note (i): The method used to determine the danger zone is illustrated in Figure (a) TR37.

Note (ii): At each competition site, a danger zone plan for display at the venue should be prepared that plots the danger zone for the location of each throwing cage considering its configuration and orientation.