

## D. THROWING EVENTS FOR SEATED ATHLETES

### Rule 34: General Conditions

#### *Official Implements*

1. The implements used (not otherwise unique to Para Athletics) shall comply with current World Athletics specifications. Only those implements which hold a current valid World Athletics Product Certificate of approval may be used at WPA Recognised Competitions (see Part B - 3.1.2).

The Para Athletics Implement Weights lists are set out in Appendix 1.

*Note: In WPA Recognised Competitions under Part B - 3.1.2, athletes must only use the implement weights relevant to their Sport Class (as outlined in Appendix 1).*

2. The weights of Implements listed in Appendix 1 and not otherwise identified by World Athletics specifications must be verified by the Technical Delegate to confirm the implement is compliant.

*Note: This refers to implements unique to Para Athletics that are not documented within World Athletics Rule 187 or related appendices.*

3. Except as provided below, all such implements shall be provided by the LOC. The Technical Delegate(s) may, based on the relevant Technical Regulations of each competition, allow athletes to use their own implements or those provided by a supplier, provided that such implements are World Athletics certified or, those implements that are not on the World Athletics list of certifiable implements which must be measured, verified and marked as approved by the LOC and approved by the Technical Delegate(s) before being made available to all athletes for use in competition. Such implements will not be accepted if the same model is already on the list of those provided by the LOC.
4. No modification shall be made to any implements during the competition.

#### *Assistance*

5. The following shall be considered assistance and are therefore not allowed:

- a) The taping of two or more fingers together. If taping is used on the hands and fingers, it may be continuous provided that as a result no two or more fingers are taped together in such a way that the fingers cannot move individually. The taping should be shown to the Chief Judge before the event starts.
  - b) The use of any device of any kind, including weights attached to the body, which in anyway provides assistance when making a trial;
  - c) Use of gloves except for athletes in Classes F31-33 and F51-53 that is not in contravention Rule 34.6 (d);
6. The following shall not be considered assistance and are therefore allowed:
- a) The use by an athlete, in order to obtain a better grip, of a suitable substance on their hands only. Shot putters may use such substances on their neck;
  - b) The placement by an athlete, in the Shot Put, Discus Throw and Club Throw, on the implement, of chalk or a similar substance. All substances used on the hands and on the implements shall be easily removable from the implement using a wet cloth and shall not leave any residue;
- COMMENT:** It is important to note that this applies to Shot Put, Discus Throw and Club Throw only. A javelin thrower may not apply any substance to the implement. However, there is no provision which would restrict a javelin thrower from using any substance on their hands (but not the implement) that complies with Rule 34.6 (a).
- c) The use of taping on the hands and fingers that is not in contravention of Rule 34.5 (a);
  - d) The use of gloves that is not in contravention of Rule 34.5 (c);

Athletes in Sport Classes F31-33 and F51-53 (i.e., quadriplegic athletes) use strapping or a glove on their non-throwing hand and anchor/attach that hand to any part of the throwing frame within the vertical plane of the throwing circle.

### ***Throwing Circle***

7. The rim of the circle shall be made of band iron, steel or other suitable material, the top of which shall be flush with the ground outside. The ground surrounding the circle may be concrete, synthetic, asphalt, wood or any other suitable material.

The interior of the circle may be constructed of concrete, asphalt or some other firm but not slippery material. The surface of this interior shall be level and  $2\text{cm}\pm 6\text{mm}$  lower than the upper edge of the rim of the circle.

In the Shot Put, a portable circle meeting these specifications is permissible.

Surface of Tie-down Devices (Sport Classes F31-34 and F51-57)

- a) WPA Approved Tie-down Devices must be used to conduct seated throwing events at WPA Recognised Competitions (see Part B - 3.1.2);
- b) At the Paralympic Games and WPA Championships (see Part B - 3.1.2 (a) and (b)) the interior of the Throwing Circle should be constructed of concrete, asphalt or a similar non-slippery material;
- c) Where portable WPA Approved Tie-down Devices are being used the surface must provide similar grip to a concrete throwing surface (e.g., coated in gritty paint OR covered in “gritty tape”);
- d) Movable platforms can be used at the discretion of the Technical Delegate. The platform does not have to be a full circle, but in these circumstances the front arc or semi-circle must be designed to give the same effect of throwing from a circle, diameter 2.135m to 2.5m and not alter the angle of the sector.

**COMMENT:** The throwing platforms are becoming more available and more widely used. It is most important to ensure that they are adequately secured to the ground so that even the largest and heaviest of athletes cannot dislodge them during the throwing action.

8. All Seated Throwing Events (Shot Put, Discus Throw, Javelin Throw and Club Throw) should be conducted from a circle with diameter of  $2.135\text{m}\pm 0.005\text{m}$  or  $2.50\text{m}\pm 0.005\text{m}$ , using a 34.92 degree sector. The rim of the circle shall be at least 6mm thick and shall be white. The use of movable platforms meeting these specifications is permissible.

*Note (i): The circular ring should preferably be coloured other than white so that the white lines required by this Rule are clearly visible.*

*Note (ii): Discus Throw and Club Throw shall be conducted from a cage.*

### ***Trials and Measurement***

9. In all Seated Throwing Events, it shall be a failure:

- a) if the shot, the discus, the club, or the head of the javelin in contacting the ground when it first lands touches the sector line, or the ground or any object (other than the cage) outside the sector line.

*Note: It will not be considered a failure if the discus strikes the near side of the cage (right side for a right-handed thrower when facing the landing sector or the left side for a left-handed thrower when facing the landing sector) after the release of the implement, then lands within the landing sector outside the limits of the cage, provided that no other Rule is infringed, including Rule 30.16.*

- b) if an athlete touches any holding straps outside the vertical plane of the rim of the throwing circle.

10. In all Seated Throwing Events, distances shall be recorded to the nearest 0.01m, rounded down to the nearest 0.01m if the distance measured is not a whole centimetre.

11. The measurement of each throw shall be made immediately after each valid trial (or after an immediate oral protest made under Rule 50.5):

- a) from the nearest mark made by the fall of the shot or discus to the inside of the circumference of the circle along a line to the centre of the circle;
- b) from where the head of the javelin first struck the ground to the inside of the circumference of the circle along a line to the centre of the circle;
- c) from the first point of contact by any part of the club to the inside of the circumference of the circle along a line to the centre of the circle.

## **Rule 35: Seated Throwing Requirements**

(Sport Classes F31-34, F51-57)

*[Note to officials: for the purpose of interpreting this rule and other rules regarding the shape, dimensions, construction and other characteristic of competition equipment, the 'fundamental principles' set out in Part B – 7.1 regarding 'Technology and Equipment' should be observed.]*

## 1. Throwing Frame Specifications:

- a) The maximum height of the seat surface, including any cushioning, shall not exceed 75 cm;
- b) Each throwing frame must have a seat which is square or rectangular in shape and each side at least 30 cm in length. The seat surface must be level or with the front higher than the back (i.e. inclined backwards).

*Note: The front is the plane furthest from the athlete's spine with the athlete in a seated position regardless of the direction of the athlete in relation to the landing area.*

- c) The throwing frame may incorporate side, front and back rests for the purposes of safety and stability. They can either be made of non-elastic fabric (e.g., non-elastic canvas) or be a rigid construction that does not move (e.g., rigid steel or aluminium). The backrest may incorporate cushioning that must not exceed 5 cm in thickness.

*Note: The structure of the throwing frame shall not impede the view of judges.*

- d) The side, front and back rest should not incorporate springs or movable joints or any other feature that could assist with propulsion of the throwing implement;
- e) The throwing frame may have a rigid vertical bar. The vertical bar must be a single, straight piece of material without curves or bends, and with a cross-sectional profile that is circular or square, not oval or rectangular. It must not incorporate springs or movable joints or any other feature that could assist with propulsion of the throwing implement;

*Note (i): It is understood that most materials will flex and distort to some degree under pressure and it will not be practical or economically viable to engineer a solution whereby all flexing is totally eliminated. However, flexing must not be clear to the naked eye and in the opinion of the technical officials the spirit of these rules and Part B - 7 is being breached.*

*Note (ii): The vertical bar may have layers of tape and/or any other suitable material to provide a better grip. The thickness of the tape or other alternative material must not result in any unfair advantage exceeding the athlete's physical prowess. Any tape on the vertical bar must be uniform except for incidental overlapping and must not result in any sudden change in diameter, such as the creation of any ring on the vertical bar. Only regular taping in accordance with the rule is allowed on the vertical bar – rings, loops and*

*the like are not permitted.*

*Note (iii): For the avoidance of doubt, an athlete shall be entitled to hold on to any component of the throwing frame for stability.*

**COMMENT:** There is no minimum or maximum length requirement for the vertical bar. The bar must be vertical however some deviation from “exactly perpendicular to the ground” may be permitted. Such deviation should not usually exceed 5 degrees from the vertical. An additional piece which acts as support to the vertical bar (similar to the example illustrated below) is permitted and strongly encouraged to mitigate against potential flexing of the vertical bar. The vertical bar, or any of its supports, may not protrude outside the throwing circle or platform.

The use of a plumb bob will assist in determining if any part of the throwing frame or vertical bar is not in conformity with this rule when placed in the throwing circle or platform.

It should also be noted that at the Paralympic Games and WPA Championships a courtesy pre-check of throwing frames is conducted to enable athletes to make any necessary amendments prior to final check at the entry to the Call Room.

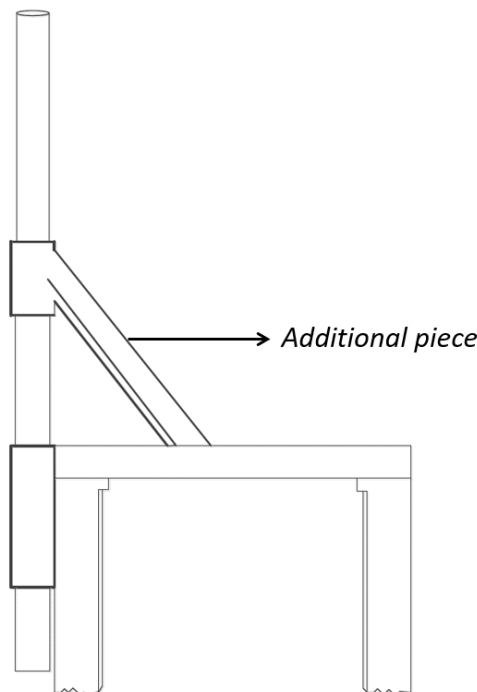

Figure 22 – Additional piece to mitigate the potential flexing of the vertical bar

- f) No part of the throwing frame, including any vertical bar, shall move (save for incidental movement that cannot reasonably be eliminated) during the throwing action.

The corner(s) of, or notches in, the seat surface may be cut to accommodate side, front, back rests and/or a vertical bar into the main throwing frame. The size of these cuts shall not be appreciably more than the space needed to insert the rests or the vertical bar in them. The overall shape of the seat shall remain square or rectangular.

- g) Footplates, if used, are for support and stability only.
- h) A daily wheelchair that satisfies these criteria is acceptable (including the requirement that it must not move during the throwing action).

## 2. Throwing Frame Measurement and Inspection

Throwing Frames will be measured and inspected in the Call Room or at the competition area prior to the commencement of the event. Once it has been measured and inspected an athlete's Throwing Frame must not be taken from the competition area before the start of the event. Throwing Frames can be re-examined by the officials before, during or after the event.

*Note: Measurement will always take place without the athlete sitting in the frame.*

## 3. Athlete's Responsibility for Throwing Frame Compliance

It is the responsibility of the athlete to ensure that their Throwing Frame conforms to the requirements stipulated in Rule 35.1. No event shall be delayed while an athlete makes adjustments to their throwing Frame. If an athlete fails to comply with this Rule, then the athlete will not be permitted to start the event and shall be shown in the results as "DNS" in accordance with Rule 6.16.

## 4. Positioning of the Throwing Frame

When positioning and securing the throwing frame inside the competition area all parts of the throwing frame, vertical bar and footplates must remain inside the vertical plane of the rim of the circle throughout the trial. Personal strapping securing the athlete to the throwing frame is not considered to be part of the throwing frame for the purposes of this rule.

## 5. Time Allocation for Securing Frames

A reasonable amount of time will be permitted for an athlete's throwing frame to be secured

in the circle before the athlete attains a seated position on the throwing frame. The maximum time allowed is for athletes to secure themselves to the chair and have as many warm-up throws as time permits is:

- a) 4 minutes for Sports Classes F32-34 and F54-57, or
- b) 5 minutes for classes F31 and F51-53.

*Note (i): Timing should begin at the time the chair is oriented, secured to the throwing platform and made available to the athlete to secure themselves into position.*

**COMMENT:** Timing for securing the athlete into the throwing chair and conducting practice throws begins when the throwing frame is situated in the circle or throwing platform. If the time in this rule elapses prior to securing the athletes into the Throwing chair, the time for the first trial should commence as it would if the athlete was secured.

If the athlete is using a day chair that meets the requirements for a throwing frame the time starts when the day chair is placed and strapped in the throwing circle or on the throwing platform.

#### 6. Tie-down Device Failure (Sport Classes F31-34, F51-57)

If a tie-down device should break or fail during the execution of a throw then the overseeing official should:

- a) If the athlete does not fail, offer the athlete the option of re-taking that trial (i.e., if the athlete is happy with the distance and they haven't failed then the athlete has the option of counting the affected trial), or;
- b) If the athlete fails, then the trial should not be counted and the athlete should be allowed to retake the affected trial.

## **Rule 36: Seated Throwing Technique, Lifting and Failure**

- 1. In Seated Throw Events, all athletes (Sport Classes F31-34, F51-57) shall throw implements from a Throwing Frame in a seated position. The seated position is defined as follows:
  - a) The athlete must sit so that both legs are in contact with the seat surface from the back of the knee to the back of the buttock (Ischial tuberosity). For athletes with lower limb above and through knee amputation, the residual length of the leg(s) must be in contact



with the seat surface till the back of the buttock (Ischial tuberosity).

- b) This sitting position must be maintained throughout the throwing action until the implement has landed. Strapping across the upper thighs and or pelvis is encouraged. Strapping must be only to the frame with non-elastic material.

*Note (i): The intention of this rule is to minimise the contribution of the legs to the athlete's performance.*

*Note (ii): If an athlete presents with anatomical limitation that prevents adherence to the above requirements, then an assessment shall be made by WPA in advance of the event. WPA shall establish a process for such exception to be granted so that the athlete is throwing within the spirit of the rules.*

*Note (iii): For the purposes of this rule, the back of the buttock refers to the most posterior part of the buttock which remains in contact with the seat surface when the athlete is seated and bends as far forward as possible at the hips, so that chest goes towards the knees and the ischial tuberosities remain in contact with the seat surface.*

*Note (iv): It is not necessary for both knees to be in contact with the same plane of the vertical edge of the seat surface provided that all other requirements of this rule are satisfied to the effect that the athlete may "straddle" the corner of the vertical edge of the seat surface with one leg on adjacent planes.*

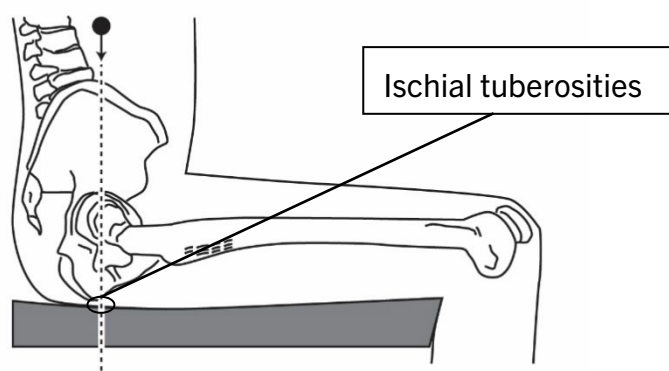

*Figure 23 Ischial tuberosities*

2. An athlete shall commence their trial from a stationary seated position.
3. It shall be a failure if an athlete moves from the seated position from the time the athlete takes the implement into the starting position of the trial until the implement has landed.

*Note: It is not a failure as long as any part of the back of the knee is in contact with the seat during the throwing action until the implement has landed.*

**COMMENT:** It is important to note that if one or both knees slide forward and lose contact with the seat surface during the throwing action, it shall be considered a failure.

### **Team of Officials**

For Seated Throw Events, it is recommended to allocate the available officials as follows:

- 1) The Chief Judge will watch over the whole of the event.
- 2) Judges checking whether the trial has been made correctly including:
  - a) observing if the knee “slides forward” off the seat cushion;
  - b) observing whether the seated position has been maintained throughout the trial in accordance with the Rules; and
  - c) observing whether the vertical holding bar flexes and measuring the trial. One must be provided with two flags - white to indicate if the trial is valid and red if it is a failure. Where EDM is not in use the second judge should pull through and hold the measuring tape in such a way that it passes through the centre of the circle.
- 3) Judge immediately after the trial placing a marker indicating the point from which the trial is to be measured.
- 4) Judge positioning the spike/prism at the point where the marker has been placed ensuring the tape is on the zero mark.
- 5) Judge in charge of retrieving the implements and returning them to the implement stand or placing them in the return chute.
- 6) Judge - a recorder scoring the results sheet and calling each athlete (and the one who is to follow).
- 7) Judge in charge of the scoreboard (trial-number-result).
- 8) Judge in charge of the clock indicating to the athletes that they have a certain time to take

their trial.

9) Judge in charge of athletes.

10) Judge in charge of the implement stand.

Note (i): This is the traditional setting-up of the officials. In major competitions, where a data system and electronic scoreboards are available, specialised personnel are certainly required. To be clear in these cases, the progress and scoring of a Field Event is followed by both the recorder and by the data system.

Note (ii): Officials and equipment must be placed in such a way as not to obstruct the athlete's way nor impede the view of the spectators.

Note (iii): As a safety precaution it is recommended to delay handing the implement to the athlete until the landing area is clear.

Note (iv): The clock should be positioned such that the athlete can easily see it. It may therefore need to be moved for each athlete.

## **Rule 37: Club Throw**

### ***The Competition***

1. The club shall be held at its neck and/or head with one hand only. It may be thrown either from a position facing the landing sector or from a position facing backward and throwing overhead.

### ***The Club***

2. Construction. The Club shall consist of four main parts: a head, a neck, a body and an end. The head, neck and body shall be solid and made of wood so as to constitute a fixed and integrated whole. The body shall have fixed it to a cylindrical end constructed of metal without indentations, projections or sharp edges.
3. The surface of the head, neck and body shall be smooth and have no dimples or pimples, grooves or ridges, holes or roughness.